

# R08IP8M-RTU1ML

8.4inch military rugged tablet with Intel® Pentium® N4200



## KEY FEATURES

- Intel® Pentium® N4200 Apollo Lake Processor, 8.4inch military rugged tablet
- 8.4" 800 x 600 Resolution Transflective TFT-LCD Panel
- With daylight-readable screen 600 nits optical bonding for clarity increasing and readability enhancing
- Ecological seals protect ports as well as connectors from moisture and dust
- Adjustable Kickstand that is Convertible to a handle
- Magnesium Alloy Housing with All-Around Elastomeric Rubber
- MIL-STD-38999 connector for LAN/USB2.0, RS232/RS422 and DC Power Input



## SPECIFICATIONS

Display			
<b>Resolution</b>	800x600	<b>Size</b>	8.4 inches
<b>Contrast Ratio</b>	600:1	<b>Panel Brightness</b>	600 nits
<b>View Angles</b>	75,75,60,70	<b>Touch / Glass</b>	Resistive Touch Screen
System Specification			
<b>Processor</b>	Intel® Pentium® N4200 Apollo Lake 1.1 GHz (up to 2.5 GHz)	<b>Memory</b>	SO-DIMM, 4GB DDR3L 1866 MHz SO-DIMM, 8GB DDR3L 1866 MHz (Optional)
<b>Storage</b>	64GB M.2 SSD 128GB M.2 SSD (Optional) 256GB M.2 SSD (Optional) 512GB M.2 SSD (Optional)	<b>Security</b>	TPM 2.0
<b>Operating System</b>	Windows 10 IoT Enterprise 64bit	<b>WLAN</b>	802.11 a/b/g/n/ac
<b>BT</b>	Support	<b>WWAN</b>	4G/ LTE or 3G (Optional)
<b>GNSS</b>	Supports GPS GLONASS, Galileo, BeiDou (Optional)		
Mechanical			
<b>Dimension</b>	266 x 222 x 50 mm	<b>Weight</b>	2.4 kg
<b>Enclosure</b>	Aluminum Magnesium Alloy Housing with Protective Rubber	<b>Cooling System</b>	Fanless Design
Power			
<b>Battery</b>	11.1V, 5200mAh Lithium-Ion Battery (6cells)	<b>Battery Operating Time</b>	8 Hours
<b>Power Rating</b>	9-36V DC in (MIL-DTL-38999/1 connector)	<b>Adapter</b>	100-240V, 50-60Hz / 19V DC
Environment			
<b>Operating Humidity</b>	10% to 90% RH, non-condensing	<b>Operating Temperature</b>	-20°C to 60°C (AC mode), -10°C to 50°C (Battery mode)
<b>Storage Temperature</b>	-30°C to 70°C (-22°F to 158°F)	<b>Shock</b>	MIL-STD-810G Method 516.6 Procedure I
<b>Vibration</b>	MIL-STD-810G Method 514.6 Procedure I	<b>IP rating</b>	IP54
<b>Drop</b>	MIL-STD-810G Method 516.6, 4 ft		

<b>Certification</b>	
<b>Certification</b>	CE, FCC
<b>Control</b>	
<b>Button</b>	1 x Power, 1 x Menu, 3 x Function Key, 2 x Brightness Control Key
<b>Accessory</b>	
<b>Accessory</b>	Adapter and Power Cord Standard Battery Quick Start Guide Manual & Driver CD Touch Stylus MIL-STD-38999 cable for External connecting
<b>Optional Accessory</b>	Adjustable Kickstand (Optional) Multi-functional Desktop Docking station (Optional) Vehicle Mounting Charger Kit (Optional) Car Power Charger (Optional) Hand Strap (Optional) Shoulder Strap (Optional) Soft Shell Case (Optional) Carry Bag (Optional)
<b>IO Ports</b>	
<b>USB Port</b>	2 x USB 3.0, 1 x USB 2.0(MIL-STD-38999 connector)
<b>SD Card Slot</b>	1 x Micro SD Slot
<b>Audio</b>	2 x 1 Watt Speaker
<b>Indicator</b>	4x LED Indicator for Power, Battery, SSD, RF status
<b>Camera</b>	
<b>Front Camera</b>	2MP Front Camera (Optional)
<b>Rear Camera</b>	5MP Rear Camera with auto-focus (Optional)

## DIMENSIONS UNIT:MM

### 8.4inch military rugged tablet R08IP8M-RTU1ML

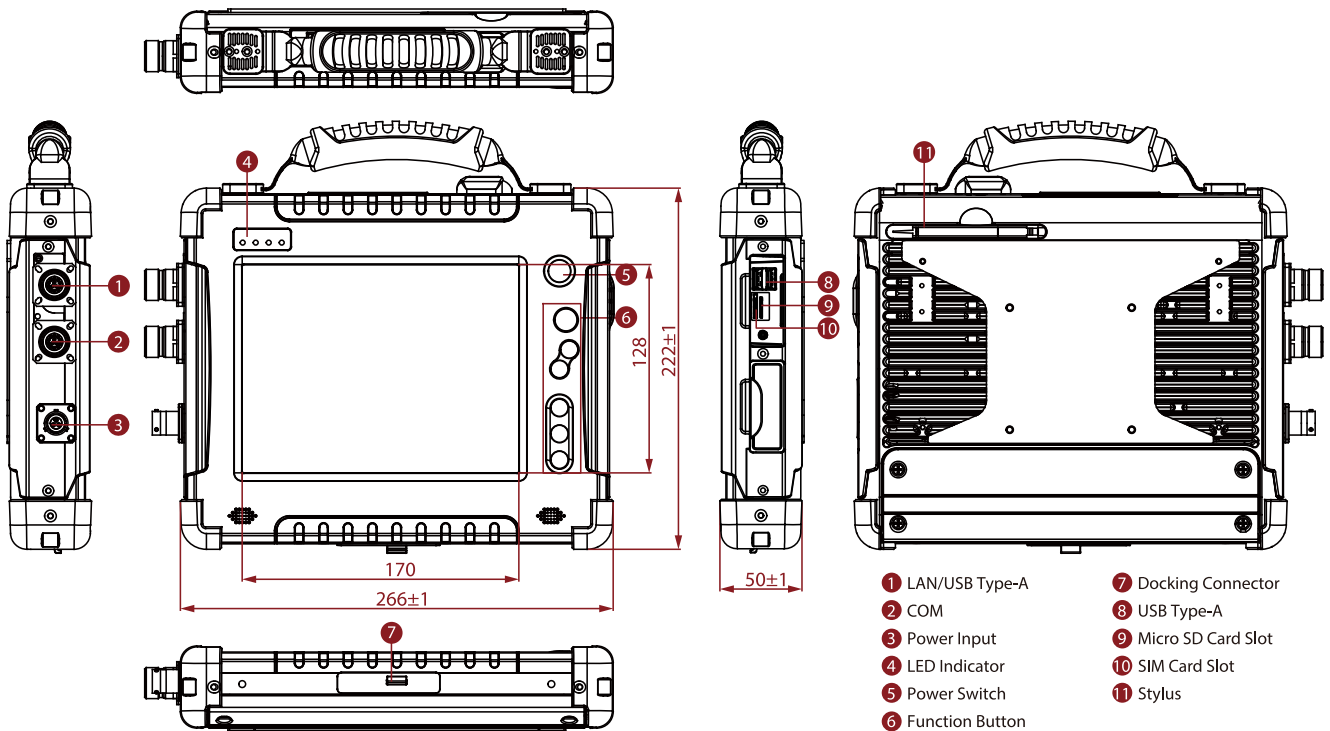

\*MIL-STD-38999 connector for LAN/USB2.0, RS232/RS422 and DC Power Input.

## NOTE

1. Measured at dimming LCD brightness. Varies depending on the usage conditions or when an external device is attached.
2. This is a simplified drawing, and some components are not marked in detail.
3. Default uses the silver military connector with RoHs, optional green military connector without RoHs.