

W10L100-GSH2

10.1" G-WIN GS Series Display



KEY FEATURES

- 10.1" 1280 x 800 Resolution
- Projected Capacitive Multi-Touch (PCAP)
- Full IP65 Water and Dust Proof
- M12 Waterproof Connectors
- Fully rugged elegant, edge-to-edge design



SPECIFICATIONS

Display	
Resolution	1280x800
Contrast Ratio	800:1
Display Color	16.7M Colors
Active Area	216.96 x135.6 mm
Size	10.1 inches
Panel Brightness	350 nits 1000 nits(Optional)
View Angles	85,85,85,85
Touch / Glass	Projected Capacitive Multi Touch Screen Protection Glass (Optional) Anti-glare Coating (Optional)
Environment	
Operating Humidity	10% to 95% RH
Storage Temperature	-30°C to 60°C
Vibration	1.48/1.90/2.24 g rms for XYZ/ 5-500Hz
Operating Temperature	-15 °C to 55 °C
Shock	40g for 11ms
IP rating	Full IP65
Certification	
Certification	Compliant with MIL-STD-810F/G for vibration / shock, CE, FCC
IO Ports	
USB Port	1 x USB for Touch Screen
Video	1 x VGA
Mechanical	
Dimension	263.28 x 172 x 40.2 mm
Enclosure	Metal Housing with Aluminum Bezel
Mounting	VESA Mount/ Panel Mount
Cooling System	Fanless Design
Accessory	
Accessory	Quick Start Guide(Hardcopy) AC Adapter(For 7" Display only) M12 Power Cable(Not Supplied with 7" Display) VGA Cable USB for Touch Cable I/O Protective Cap x 3
Power	
Power Rating	9-36V DC (M12 type)
Control	
Button	5 Keys: -, +, Power, Esc, Enter

DIMENSIONS UNIT:MM

Winmate W10L100-GSH2

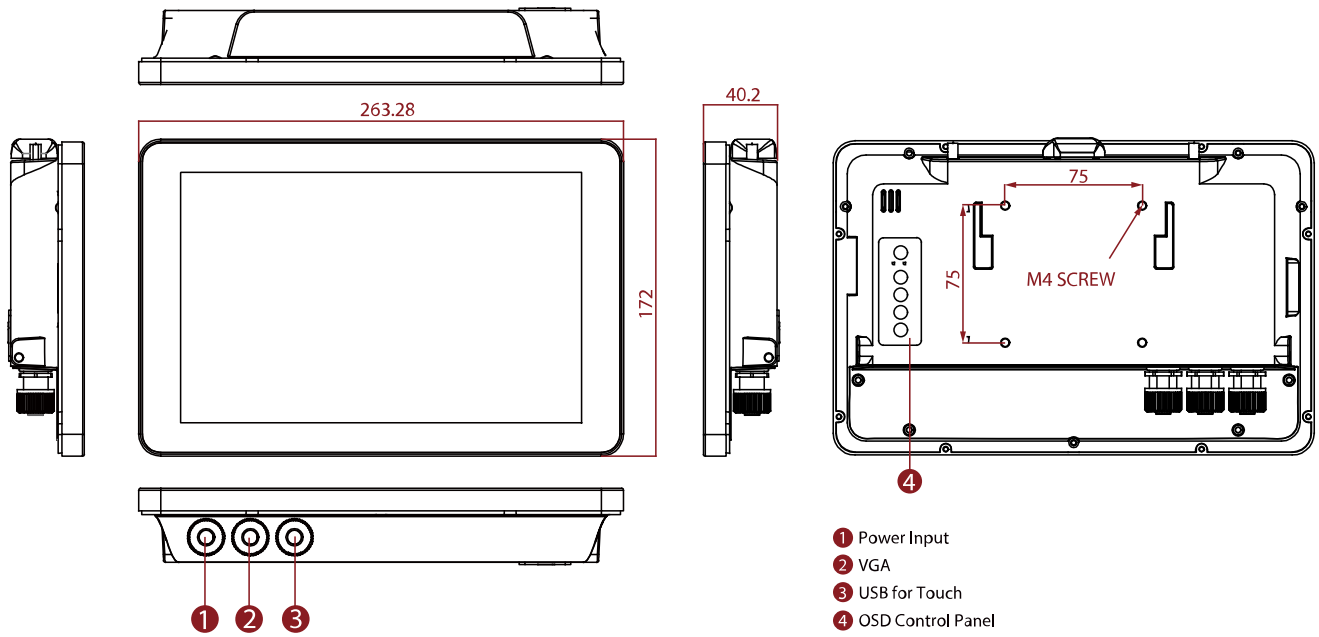

NOTE

1. This is a simplified drawing and some components are not marked in detail.
2. The product shown in this datasheet is a standard model. For diagrams that contain customized or optional I/O, please contact the Winmate Sales Team for more information.
3. All specifications are subject to change without prior notice.